

High Efficiency

Pilot Operated Safety Valves

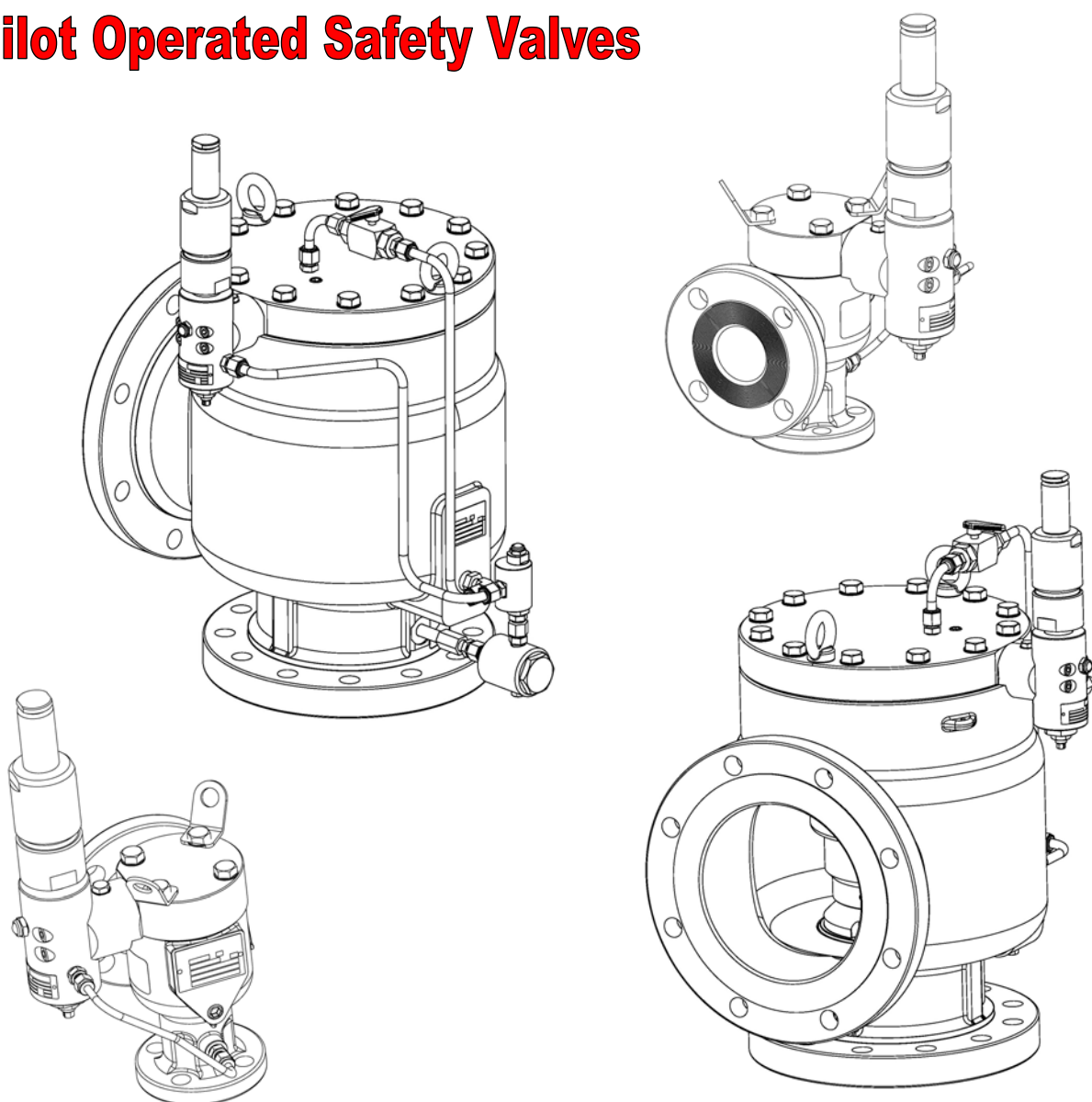

Product Description

Technical High Efficiency Pilot Operated Safety Valves are derived from the conventional valves of the same series, and retain the same orifices. They are designed and manufactured in accordance to the API 526 standard.

The full range of size from 1"x2" up to 8"x10" with all orifice from D – T is available for pressure ratings up to pressure class 2500x600.

Their main feature is the adjustable blowdown from 2% to 7% of set pressure and the pilot that can be "pop action or modulate type

The models currently available are full nozzle or semi nozzle type and include, as standard accessories, the backflow preventer and the strainer.

The pilot operated safety valves are used mainly in the Oil & Gas industry and share with the "mother series" the range of available materials. These valves can be customized with the following accessories: field test connector, manual opening device, soft seat...etc.

The available certifications are: PED, GOST-R, GGTN-K.



Benefits

- ✚ Higher operating pressure, short blowdown (higher plant efficiency)
- ✚ Seat tightness up to set pressure (low vibration sensitivity)
- ✚ Immediate full lift (maximum discharge)
- ✚ Medium loss is minimized



CHARACTERISTICS

Discharge coefficient: Gas **K=0,94**
Liquid **K=0,6**

- PED Approval;
- Zero Overpressure;
- 2 ÷ 7 blowdown pressure;
- adjustment as shown in the spring range;
- connection: Ansi, UNI, DIN, AFNOR, etc.

ACCESSORIES

- Field test connection;
- Backflow preventer (standard)
- Inlet screen (standard)
- Pilot supply Filter
- Manual opening device;
- Remote Sensing ;
- Pilot test gag;
- Soft sealing

Orifices & Dimensions

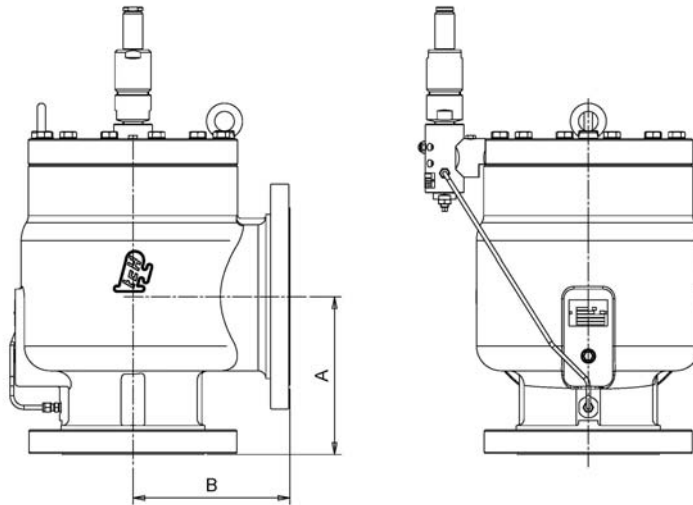

Data in accordance with API 526

ORIFICE	SIZE	INLET			OUTLET			DIMENSIONS			
		Max Set Pressure		Class	Class	Max Backpressure		A	B		
		bar	psig	ANSI	ANSI	bar	psig	mm	mm		
D Ø 10 0.785 cm ² 0.121 sq.in	1" x 2"	19.6	285	150	150	19.6	285	104.8	114.3		
		51	740	300	150	19.6	285	111.1	114.3		
		102	1480	600	150	19.6	285	111.1	114.3		
		153	2220	900	300	51	740	125.4	120.7		
		255	3705	1500	300	51	740	125.4	120.7		
	1½" x 2"	425	6170	2500	300	51	740	125.4	120.7		
		19.6	285	150	150	19.6	285	123.8	120.7		
		51	740	300	150	19.6	285	123.8	120.7		
		102	1480	600	150	19.6	285	123.8	120.7		
		153	2220	900	300	51	740	149.2	139.7		
		255	3705	1500	300	51	740	149.2	139.7		
		425	6170	2500	300	51	740	149.2	139.7		
		E Ø 13.3 1.389 cm ² 0.215 sq.in	1" x 2"	19.6	285	150	150	19.6	285	104.8	114.3
				51	740	300	150	19.6	285	111.1	114.3
102	1480			600	150	19.6	285	111.1	114.3		
153	2220			900	300	51	740	125.4	120.7		
255	3705			1500	300	51	740	125.4	120.7		
1½" x 2"	425		6170	2500	300	51	740	125.4	120.7		
	19.6		285	150	150	19.6	285	123.8	120.7		
	51		740	300	150	19.6	285	123.8	120.7		
	102		1480	600	150	19.6	285	123.8	120.7		
	153		2220	900	300	51	740	149.2	139.7		
	255		3705	1500	300	51	740	149.2	139.7		
	425		6170	2500	300	51	740	149.2	139.7		
	F Ø 16.6 2.164 cm ² 0.335 sq.in		1" x 2"	19.6	285	150	150	19.6	285	104.8	114.3
				51	740	300	150	19.6	285	111.1	114.3
102		1480		600	150	19.6	285	111.1	114.3		
153		2220		900	300	51	740	125.4	120.7		
255		3705		1500	300	51	740	125.4	120.7		
1½" x 2"		425	6170	2500	300	51	740	125.4	120.7		
		19.6	285	150	150	19.6	285	123.8	120.7		
		51	740	300	150	19.6	285	123.8	120.7		
		102	1480	600	150	19.6	285	123.8	120.7		
		153	2220	900	300	51	740	149.2	139.7		
		255	3705	1500	300	51	740	149.2	139.7		
		425	6170	2500	300	51	740	149.2	139.7		

Orifices & Dimensions

ORIFICE	SIZE	INLET			OUTLET			DIMENSIONS	
		Max Set Pressure		Class	Class	Max Backpressure		A	B
		bar	psig	ANSI	ANSI	bar	psig	mm	mm
G Ø 21.2 3.53 cm ² 0.547 sq.in	1½" x 3"	19.6	285	150	150	19.6	285	130.2	123.8
		51	740	300	150	19.6	285	130.2	123.8
		102	1480	600	150	19.6	285	130.2	123.8
		153	2220	900	300	51	740	161.9	171.5
		255	3705	1500	300	51	740	161.9	171.5
		425	6170	2500	300	51	740	161.9	171.5
	2" x 3"	19.6	285	150	150	19.6	285	136.5	123.8
		51	740	300	150	19.6	285	136.5	123.8
		102	1480	600	150	19.6	285	136.5	123.8
		153	2220	900	300	51	740	166.7	171.5
		255	3705	1500	300	51	740	166.7	171.5
		425	6170	2500	300	51	740	177.8	171.5
H Ø 26,5 5,515 cm ² 0,854 sq.in	1½" x 3"	19.6	285	150	150	19.6	285	130.2	123.8
		51	740	300	150	19.6	285	130.2	123.8
		102	1480	600	150	19.6	285	130.2	123.8
		153	2220	900	300	51	740	161.9	171.5
		255	3705	1500	300	51	740	161.9	171.5
		425	6170	2500	300	51	740	161.9	171.5
	2" x 3"	19.6	285	150	150	19.6	285	136.5	123.8
		51	740	300	150	19.6	285	136.5	123.8
		102	1480	600	150	19.6	285	136.5	123.8
		153	2220	900	300	51	740	166.7	171.5
		255	3705	1500	300	51	740	166.7	171.5
		425	6170	2500	300	51	740	177.8	171.5
J Ø 34 9,079 cm ² 1,407 sq.in	2" x 3"	19.6	285	150	150	19.6	285	136.5	123.8
		51	740	300	150	19.6	285	136.5	123.8
		102	1480	600	150	19.6	285	136.5	123.8
		153	2220	900	300	51	740	166.7	171.5
		251.7	3650	1500	300	51	740	166.7	171.5
		255	3705	1500	600	102	1480	166.7	171.5
		251.7	3650	2500	300	51	740	177.8	171.5
	3" x 4"	425	6170	2500	600	102	1480	177.8	171.5
		19.6	285	150	150	19.6	285	155.6	161.9
		51	740	300	150	19.6	285	155.6	161.9
		102	1480	600	150	19.6	285	162.0	161.9
		153	2220	900	300	51	740	190.5	181.0
		255	3705	1500	300	51	740	190.5	181.0
		255	3705	1500	300	51	740	190.5	181.0
K Ø 40,6 12,94 cm ² 2,006 sq.in	3" x 4"	19.6	285	150	150	19.6	285	155.6	161.9
		51	740	300	150	19.6	285	155.6	161.9
		102	1480	600	150	19.6	285	162.0	161.9
		153	2220	900	300	51	740	190.5	181.0
		255	3705	1500	300	51	740	190.5	181.0
		255	3705	1500	300	51	740	190.5	181.0
L Ø 50,6 20,10 cm ² 3,116 sq.in	3" x 4"	19.6	285	150	150	19.6	285	155.6	161.9
		51	740	300	150	19.6	285	155.6	161.9
		85.5	1240	600	150	19.6	285	161.9	161.9
		102	1480	600	300	51	740	190.5	181.0
		155.2	2250	900	300	51	740	190.5	181.0
		200	2900	1500	300	51	740	190.5	181.0
		255	3705	1500	600	102	1480	190.5	193.7
	4" x 6"	19.6	285	150	150	19.6	285	155.6	161.9
		51	740	300	150	19.6	285	155.6	161.9
		102	1480	600	150	19.6	285	162.0	161.9
		153	2220	900	300	51	740	190.5	181.0
		255	3705	1500	300	51	740	190.5	181.0
		255	3705	1500	300	51	740	190.5	181.0
		255	3705	1500	300	51	740	190.5	181.0

Orifices & Dimensions

ORIFICE	SIZE	INLET			OUTLET			DIMENSIONS	
		Max Set Pressure		Class	Class	Max Backpressure		A	B
		bar	psig	ANSI	ANSI	bar	psig	mm	mm
M Ø 56,8 25,33 cm ² 3,927 sq.in	4" x 6"	19.6	285	150	150	19.6	285	196.9	209.6
		51	740	300	150	19.6	285	196.9	209.6
		102	1480	600	150	19.6	285	196.9	209.6
		153	2220	900	300	51	740	249.2	233.4
		255	3705	1500	300	51	740	249.2	233.4
N Ø 62,4 30,58 cm ² 4,74 sq.in	4" x 6"	19.6	285	150	150	19.6	285	196.9	209.6
		51	740	300	150	19.6	285	196.9	209.6
		102	1480	600	150	19.6	285	196.9	209.6
		153	2220	900	300	51	740	249.2	233.4
		255	3705	1500	300	51	740	249.2	233.4
P Ø 75,7 45 cm ² 6,976 sq.in	4" x 6"	19.6	285	150	150	19.6	285	196.9	209.6
		51	740	300	150	19.6	285	196.9	209.6
		90.0	1305	600	150	19.6	285	196.9	209.6
		102	1480	600	300	51	740	196.9	209.6
		155.2	2220	900	300	51	740	249.2	233.4
		212.4	3080	1500	300	51	740	249.2	233.4
		255	3705	1500	600	102	1480	249.2	233.4
Q Ø 99,6 77,91 cm ² 12,07 sq.in	6" x 8"	19.6	285	150	150	19.6	285	239.7	241.3
		51	740	300	150	19.6	285	239.7	241.3
		91.7	1330	600	150	19.6	285	246.1	241.3
		102	1480	600	300	51	740	246.1	265.1
R Ø 119,8 112,7 cm ² 17,47 sq.in	6" x 8"	19.6	285	150	150	19.6	285	239.7	241.3
		51	740	300	150	19.6	285	239.7	241.3
		63.1	915	600	150	19.6	285	246.1	241.3
		102	1480	600	300	51	740	246.1	265.1
T Ø 152,8 183,3 cm ² 28,42 sq.in	8" x 10"	19.6	285	150	150	19.6	285	239.7	241.3
		51	740	300	150	19.6	285	239.7	241.3
		62	900	600	150	19.6	285	246.1	241.3
		102	1480	600	300	51	740	246.1	265.1

Pilot " POP ACTION "

ITEM	DESCRIPTIONS	MATERIAL
1	PILOT BODY	316L st. steel
2	GUIDE	316L st. steel
3	SEAT GUIDE	316L st. steel
4	O-RING	FPM rubber
5	SPACER	316L st. steel
6	SEAT	316L st. steel
7	O-RING + BK	FPM + NBR
8	PISTON	316L st. steel
11	O-RING	FPM rubber
12	BLOWDOWN SCREW	316L st. steel
13	LOCK NUT	st. steel
14	RING NUT	316L st. steel
16	SHUTTER	316L st. steel
17	O-RING	FPM rubber
18	SEAT	316L st. steel
19	O-RING	FPM rubber
20	O-RING	FPM rubber
21	SPINDLE	316L st. steel
23	SPRING	st. steel
24	SPRING GUIDE	st. steel
25	BONNET	316L st. steel
26	LOCK NUT	316 st. steel
27	ADJUSTING SCREW	316L st. steel
28	CAP	316L st. steel
31	BONNET BASE	316L st. steel
54	BALL	316L st. steel
57	O-RING	FPM rubber
61	STRAINER	303 st. steel
62	SCREW	st. steel
63	O-RING	FPM rubber
64	O-RING	FPM rubber
65	BACKFLOW BODY	316L st. steel
66	BUSH	316L st. steel
67	SEAT BUSH	316L st. steel
68	PLUG	304 st. steel
69	GASKET	aluminium

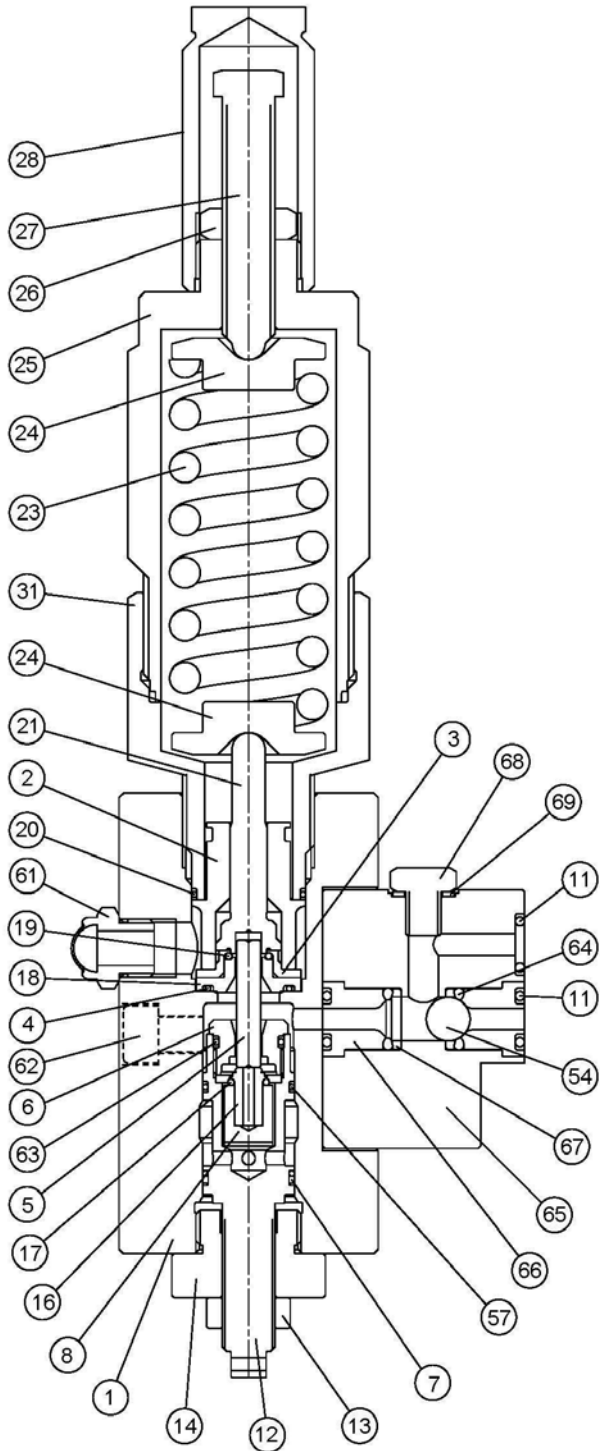

Every part and gasket can be replaced by other material according to customer specification

Pilot Operated Safety Valves

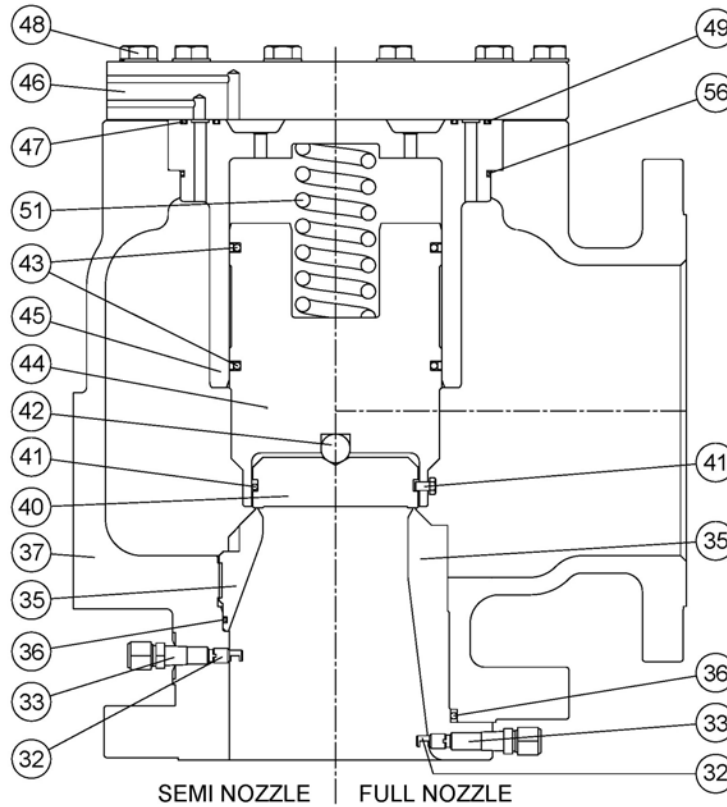

ITEM	DESIGNATION	STANDARD MATERIAL	
		CARBON STEEL	STAINLESS STEEL
32	SENSING TUBE	Stainless Steel	Stainless Steel
33	MALE CONNECTOR	316L st. steel	316L st. steel
35	NOZZLE / SEMI NOZZLE	316L + stell.	316L + stell.
36	O-RING	FPM rubber	FPM rubber
37	BODY	WCB carb. steel	CF3M st. steel
40	DISC	17-4PH steel	17-4PH steel
41	RING / SCREW	316 / 304 st. steel	316 / 304 st. steel
42	BALL	316 st. steel	316 st. steel
43	GASKET	FPM + PTFE	FPM + PTFE
44	DISC HOLDER	316L st. steel	316L st. steel
45	GUIDE	316L st. steel	316L st. steel
46	BONNET	316L st. steel	316L st. steel
47	O-RING	FPM rubber	FPM rubber
48	SCREW	st. steel	st. steel
49	O-RING	FPM rubber	FPM rubber
51	SPRING	Carbon Steel	Stainless Steel
56	O-RING	FPM rubber	FPM rubber

Every part and gasket can be replaced by other material according to customer specification

Options

1) BACKFLOW PREVENTER.

This feature prevents reverse flow which can occur when the pressure, at the outlet flange, is greater than the system pressure

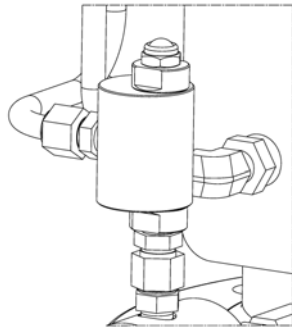
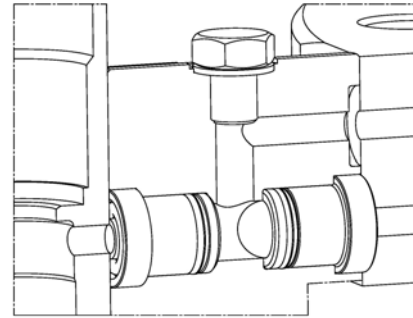

2) FIELD TEST CONNECTION

This options allows a quick and simple verification of set pressure while the valve remains in service.

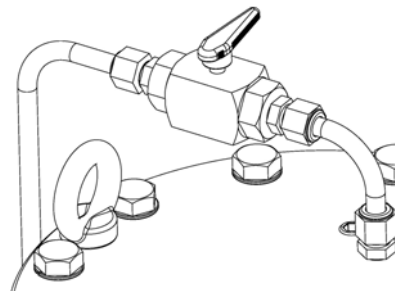

3) MANUAL OPENING DEVICE

A valve is mounted between the dome and the main valve outlet. Its opening vents the dome faster than it can be recharged by the pilot supply, so the dome pressure is reduced and the valve opens.

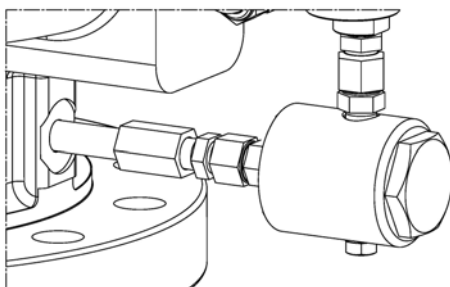

4) ADDITIONAL FILTER

This filter between pressure supply and pilot is used for fluid with large amount of particulates matter. The material is all stainless steel and the filter element can be cleaned or replaced.

5) SOFT SEALING

On main valve is available soft seat as option. (The standard application is metal to metal)

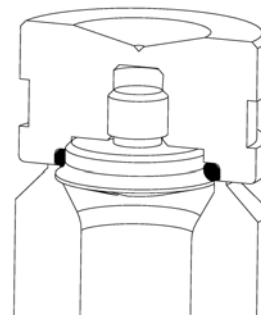

6) REMOTE SENSING CONNECTION

This option guarantees a stable operation of the valve. The pilot will operate independently of a possible pressure loss in the inlet pipe.

7) Tets gag (on the pilot)

8) Lifting lever (on the pilot)

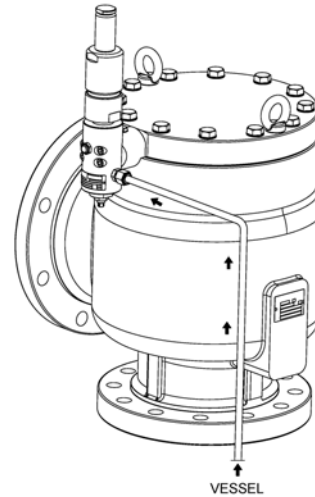

PILOT WORKING

Main characteristics :

- ⇒ Gas and Liquid Application
- ⇒ Now Flowing
- ⇒ Working pressure up to 95% of set pressure
- ⇒ Field adjustable blowdown;
- ⇒ Immediate full lift of the main valve without overpressure;

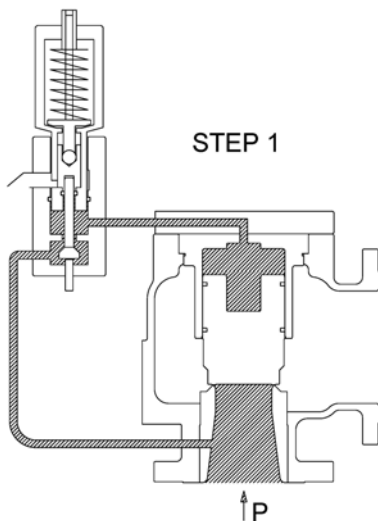
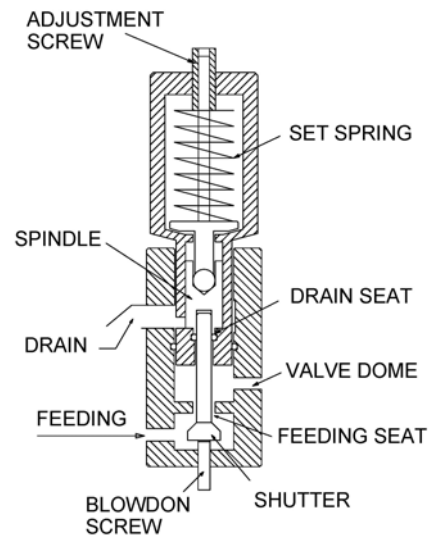

STEP 1

P < 100% of SET PRESSURE

The feeding seat of the pilot is open and the main valve's Dome is pressurised :

- THE MAIN VALVE IS CLOSED -

STEP 2

P = 100% of SET PRESSURE

The drain seat of the pilot opens and drives the closing of the feeding seat :

- THE MAIN VALVE IS OPENS -

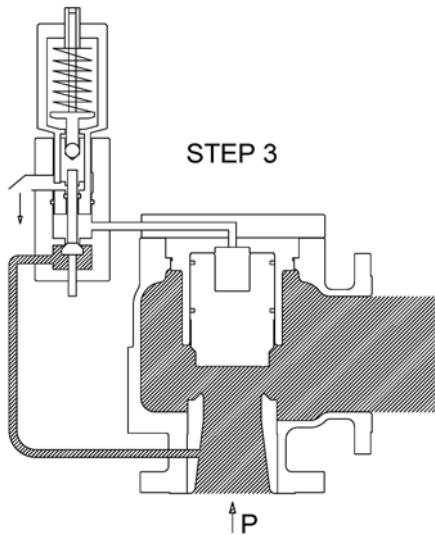
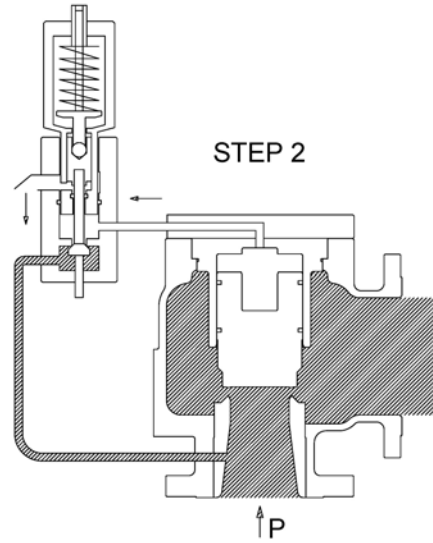

STEP 3

100% < P < 110% of SET PRESSURE

The drain seat of the pilot stays open and lets the dome to the atmosphere:

- THE MAIN VALVES STAYS OPENS -

STEP 4

P = 92 ÷ 98 % of SET PRESSURE

The drain seat recloses and drives the opening of the feeding seat:

- THE MAIN VALVE IS CLOSING -

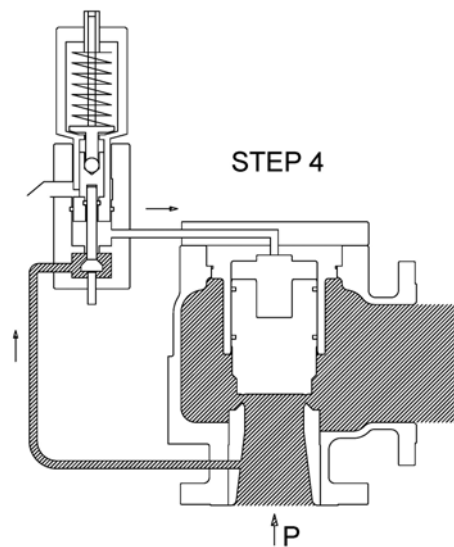

STEP 4